

The Roles of Green Perceived Value, Green Perceived Risk, and Green Trust towards Green Purchase Intention of Inverter Air Conditioner in Surabaya

Felix Aprilio Rahardjo

International Business Management Program, Petra Christian University

Jl. Siwalankerto 121-131, Surabaya

E-mail: felixapriliorahardjo@gmail.com

ABSTRACT

Environmental degradation keeps increasing every year and global warming is one of the environmental degradations that we need to face right now. The fact is air conditioner is one of the main causes of global warming. This research is done to know the impact of green perceived value and green perceived risk towards green purchase intention of inverter air conditioner in Surabaya, through the mediation of green trust. In this research, there are two independent variables and one dependent variable involved. The independent variables are green perceived value and green perceived risk, while the dependent variable green purchase intention.

In this research, there are 250 questionnaires distributed with clustered sampling method system. The analysis technique used in this research is structural equation modelling (SEM), supported with SPSS and AMOS as a tools for data analysis. The research result indicates that green perceived value will have a positive significant impact towards green purchase intention of low watt inverter air conditioner in Surabaya partially mediated by green trust. Furthermore, green perceived risk will have a negative significant impact towards green purchase intention of inverter air conditioner in Surabaya fully mediated by green trust.

Keywords: Green Perceived Value, Green Perceived Risk, Green Trust, Green Purchase Intention, Inverter Air Conditioner

ABSTRAK

Kerusakan lingkungan terus meningkat setiap tahunnya dan global warming adalah salah satu fenomena kerusakan lingkungan yang sedang kita hadapi sekarang. Faktanya, pendingin ruangan adalah salah satu penyebab utama dari global warming. Penelitian ini dilakukan untuk mengetahui pengaruh dari green perceived value dan green perceived risk terhadap green purchase intention pendingin ruangan inverter di Surabaya melalui mediasi green trust. Dalam penelitian ini akan ada dua variabel independen dan satu variabel dependen. Variabel independen dalam penelitian ini adalah green perceived value dan green perceived risk, sedangkan variabel dependen dalam penelitian ini adalah green purchase intention.

Pada penelitian ini, total 250 kuesioner telah disebar dengan system clustered sampling method. Teknik analisa yang akan digunakan pada penelitian ini adalah structural equation modelling (SEM) yang akan didukung dengan aplikasi SPSS dan AMOS untuk menganalisa data terkait. Hasil dari penelitian ini menunjukkan bahwa green perceived value berdampak positif secara signifikan terhadap green purchase intention dimediasi sebagian oleh green trust. Selanjutnya, green perceived risk berdampak negatif secara signifikan terhadap green purchase intention dimediasi penuh oleh green trust.

Kata Kunci: Green Perceived Value, Green Perceived Risk, Green Trust, Green Purchase Intention, Pendingin Ruangan Inverter

INTRODUCTION

The world is our shelter and we ought to take care of. However, nowadays environmental degradation becomes very common and even keeps increasing every year. In fact, world's environmental degradation annual cost of the global economy is reaching \$6.596 billion or 10.97% of World's total GDP in 2008 and it is expected to reach \$28,615 billion or 17,78% of World's total GDP in 2050 (Trucost, 2011).

Environmental degradation takes diverse forms, ranging from destruction of ecosystem to air pollution, water pollution, and deforestation. Nonetheless, all of these issues will take a role as significant influences that will lead to the one of world's major problems, which is the global warming (Inhabitat, 2012). Global warming is "a gradual increase in the overall temperature of the earth's atmosphere generally attributed to the greenhouse effect caused by increased levels of carbon dioxide, CFCs (chlorofluorocarbon), and other pollutant" (Oxford Dictionary, 2011). Global warming can caused the increasing of sea level, intense heat waves, growing health problems, disruption of food supplies, extreme weather events, and others (UCSUSA, 2014). Thus, nowadays there are more and more organizations start to campaigning about the importance of green lifestyle, such as WWF (World Wide Fund for Nature) and UN (United Nations) in order to increase the awareness of people's mind about the importance of green lifestyle (WWF, 2014).

By the increase of people's awareness towards the importance of green lifestyle, they also start to use green products. Green product itself has a meaning of a product which functions or ideas are related with the process of material retrieval, production, sales, utilization and waste treatment that are available for recycling, reduced pollution and energy saving (Liu & Wu, 2009). This fact is also supported by the data that showing the increase of green product sales in the world. The green product sales in the world increase from EUR 10.981 billion in 2012 to EUR 11.815 Billion in 2013 (Philip, 2013). In line with the increasing number of green products as well as people's awareness about green lifestyle, knowing what factors that will influence the purchase intention for green products is very important.

Based on Chen and Chang (2012) green purchase intention is influenced by green perceived value and green perceived risk, through the mediation of green trust. Green perceived value is the general valuation from the consumers about the advantage of the good or service that has a benefit for the environment as people expected. Green perceived risk is the probability of having negative consequences on the environment due to customer's buying behaviour. Green Trust is a willingness of using some specific trusted good, service, or brand that is believed to have positive impact on the environment. While the green purchase intention is define as the tendency of a buyer to purchase a specific product based on the environmental necessity.

By giving additional green benefits through product value, it has influence the consumers trust on the brand and

it will lead in to higher green purchase intention (Chen & Chang, 2012). Furthermore, if the consumers see your product as a risky product for the environment, they will not trust your product and they will not buy your product.

In addition, this research is specifically consider about the importance of using green marketing technique in order to make people aware about the unpleasant environmental influences. So, this will encourage the green purchase intention for specifically buying an inverter air conditioner as standard air conditioner is one of the biggest contributors to the global warming. On the other hand, other researches only talk about the concept of green marketing itself without addressing to the specific product, in this case is air conditioner itself.

Based on IPCC (Intergovernmental Panel on Climate Change), the greatest contributor of global warming comes from Electricity and Heat production, which is followed by AFOLU (Agriculture, Forestry, and Other Land Use) and industrial sector (IPCC, 2014). Lead by this fact, it cannot be denied that electricity is one of the highest contributors of global warming. Sadly, Indonesia is list in the top 15 world's largest electricity users in the world (Hijauku, 2013).

The recent research from Indonesia's statistic company, BPS (Badan Pusat Statistik) shows that household living is the largest electricity users in Indonesia with total 72.176,8 GWh or equivalent with 41.4% of Indonesia's total electricity usage (BPS, 2012), and 70% of it comes from air conditioner usage (Sarie, 2011). On the other hand, air conditioner sales keep increasing every year in Indonesia, including Surabaya. In 2013, Surabaya's air conditioner sales increase by 30% compare from the previous year (Rekohadi, 2013). This tremendous increasing number is caused by the weather of Surabaya which gets hotter and hotter.

Electronic companies take an advantage of this situation by producing an inverter air conditioner in order to answer the growth market demand as well as giving a positive contribution to the environment. Inverter air conditioner has lower electricity consumption up to \pm 50% compare to the conventional air conditioner (Neraca, 2012). Furthermore, some electronic manufacturers have developed inverter air conditioner and giving more features besides lower electricity consumption, such as non-HCFC substance which has zero potential for damaging world's ozone and lower global warming, air purifier technology for better air quality, and other great features. Thus, the usage of inverter air conditioner can help to reduce the process of global warming, while creating a healthier lifestyle at the same time (Gatra, 2015).

In fact, the demand of inverter air conditioner in Indonesia keeps increasing every year. Based on Daikin's chairman, the demand of inverter air conditioner in Indonesia is increasing by 10% in 2012 and it is expected to be doubled in the upcoming years (Neraca, 2012). Therefore, it is very important to know which factors influence the green purchase intention of inverter air conditioner.

LITERATURE REVIEW

Align with the increase of people's intention to use green products; more and more people start to find which factors will influence people's intention to purchase a certain green products. One of them is by Chen and Chang in 2012. Based on Chen and Chang (2012), green purchase intention is influenced by green perceived value and green perceived risk through the mediation of green trust, here is the model constructed.

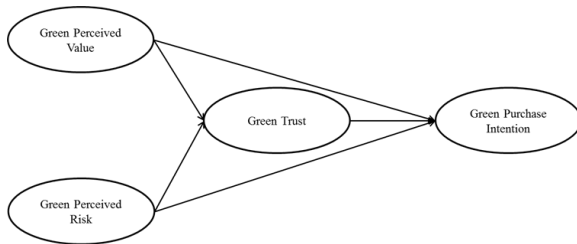

Figure1. Relationships between Concepts, based on Chen and Chang 2012

According to Chen and Chang (2012), Green perceived value will have a positive impact towards both green trust and green purchase intention, while green perceived risk will have negative impact towards both green trust and green purchase intention. Hence, in this section the author will explain each variable included within this research.

Green Perceived Value

Perceived value is the net benefits of a product or service based on consumer's general evaluation (Bolton & Drew, 1991; Patterson & Spreng, 1997). However, due to the increasing of environmental degradation and people's awareness towards environment, a theory of green perceived value is developed. Green perceived value can be defined as the general valuation from the consumers about the advantage of the good or service that has a benefit for the environment as people expected (Chen & Chang, 2012).

Green Perceived Risk

Perceived risk is a subjective assessment by the consumers which is related to the negative consequences and uncertainty that may occur due to their wrong decision (Aaker, 1996). In addition, green perceived risk is defined as the probability of having negative consequences on the environment due to consumer's buying behaviour (Chen & Chang, 2012).

Green Trust

Consumer trust is basic consideration and expectation of consumer to the extent of belief in oneself in the expectation to the other party that will lead to the long term consumer behaviour (Lee et al., 2011). Green Trust itself is a willingness of using some specific trusted good, service, or brand that is believed to have positive impact on the environment (Chen & Chang, 2012).

Green Purchase Intention

Purchase intention is the best indicator to measure consumer's response behaviour towards a specific product (Li & Biocca, 2012). Green purchase intention itself is the tendency of a buyer to purchase a specific product based on the environmental necessity (Chen & Chang, 2012). After explaining each of the variables included in this research, the author will show the propose hypotheses:

H1: Green perceived value will have an impact to green purchase intention.

The impact of green perceived value on green purchase intention can be determined through general valuation of the consumers about the green value of this specific product that will lead to the consumer's buying intention. Hence, they will be encouraged to choose this specific product compared to the other products due to its higher green perceived value.

H2: Green perceived risk will have an impact to green purchase intention.

The impact of green perceived risk on green purchase intention can be determined through the consumer's evaluation about the risk of this specific product to the environment that will automatically influence the buying intention of consumers. So, the higher the green perceived risk will affect in lowering the consumer's green purchase intention.

H3: Green perceived value will have an impact to green trust.

The impact of green perceived value on green trust can be determined through the consumer's general valuation about the green benefit of specific product for the environment. Thus, when consumer perceived the specific product with higher green value, they will tend to trust your product as less adverse impact on the environment. Hence, the higher the green perceived value will lead to higher green trust.

H4: Green perceived risk will have an impact to green trust.

The impact of green perceived risk on green trust can be determined through the consumer's evaluation about the risk of using this specific product in the concern to the environment. Thus, when consumers concern this specific product is having a higher adverse impact to the environment, they will tend to distrust your product. Hence, the higher the green perceived risk will lead to the decreasing of the green trust.

H5: Green trust will have an impact to green purchase intention

The impact of green trust on green purchase intention can be determined through consumer's judgement about the long term trust to the specific product as it has positive impact to the environment, thus it will lead to the increasing of the consumer's buying intention. So, the increasing of green trust on consumers will lead to the higher green purchase intention.

RESEARCH METHOD

In this research, the author will use causal explanatory study in order to find out the relationship between variables involved (Ghozali, 2011). The source of data within this research will be gathered both from primary and secondary data. The primary data will be gathered by distributing 250 questionnaires to the respondents around Surabaya who ever bought an inverter air conditioner. The questionnaires that are distributed will be in form of basic paper. Thus, it will be easier for the author to collect the data as well as the respondents when they have a question regarding the questionnaire. While, the secondary data will be gathered through websites, articles, journals, and books for the basis data on this research.

The measurement of the questionnaire within this research will be using Likert scale from 1 to 5 from strongly disagree to strongly agree for each indicator. The measurement of construct in this research will be based on Chen and Chang (2012), which will be broken down below.

Green Perceived Value

Based on Chen and Chang (2012), green perceived value can be measured with five terms, which are the environmental functions of the product have a very good value for people, the environmental performance of the product can be seen as good as what people expected, this specific product is chosen as it has more environmental concern compared to the other products, this specific product is chosen as its capability to be environmental friendly, and this specific product is chosen due to it has more environmental benefit compared to the other products.

Green Perceived Risk

Based on Chen and Chang (2012), green perceived risk can be measured with five terms, which are this product has a chance of having a negative side that is related to its environmental performance, this product has a probability of not working properly with respect related to its environmental design, the usage of this product has a probability of getting environmental penalty or loss, the usage of this product may affect negatively to the environment, and the usage of this product would give a negative impact to the people's reputation or image.

Green Trust

Based on Chen and Chang (2012), green trust can be measured with five terms, which are, this product can be seen as having a reliable environmental reputation, this product generally can be seen as having a trustworthy environmental performance, this product can be concerned as a dependable product for our environment, the environmental concern of the product can be seen as people are expected, and this product always provides the expected promises and commitments to its relation to the conservation of environment.

Green Purchase Intention

Based on Chen and Chang (2012), green purchase intention can be measured with three terms, which are the environmental concern becomes the main considerations to purchase a certain product, the environmental performance will influence your intention to purchase a certain product in the future, and the environmental friendly feature becomes the general reason to purchase a certain product.

For the analytical method, the author will use structural equation modelling (SEM) method, in order to analyze the whole framework. Furthermore, in this research the structural equation modelling test will be conducted using two applications, which are SPSS for SEM assumption test and AMOS for confirmatory factor analysis, path analysis, and structural model fit.

RESULTS AND DISCUSSION

The confirmatory factor analysis needs to be done for both endogenous and exogenous variables in order to determine the validity of each indicator involved (Ghozali, 2011). The confirmatory factor analysis will be done through seeing the measurement model standardized regression weight and model fit. The minimum standard of standardized regression weight is each indicator must above 0.05 (Ghozali, 2011). For the model fit, each model needs to have minimum 3 acceptable fits (Hair et al., 2010) which the standard will be shown in the table 1 below.

Table 1. Rule of Thumb for Model Fit Measurement

Model Fit Measurement	Good Fit	Acceptable Fit
GFI	≥ 0.9	0.956
AGFI	≥ 0.9	0.916
CMIN/DF	2 – 4	2.414
TLI	≥ 0.9	0.970
NFI	≥ 0.9	0.966

Now, let's begin with the measurement model of exogenous variables (Figure 2). Based on the table 2, all the indicators estimate values are above 0.5. Therefore, all of the indicators are valid. Furthermore, according to table 3, all the model fit measurements values still fulfil the cut off. GFI, CMIN/DF, TLI, and NFI have a good model fit, while the RMSEA and AGFI have an acceptable fit.

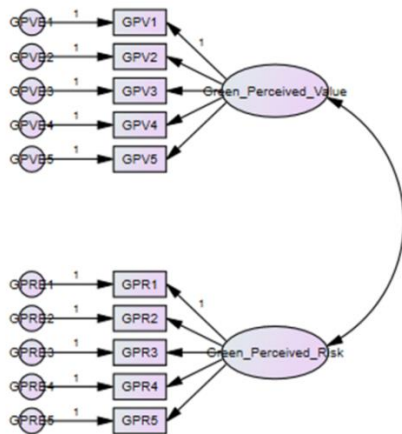

Figure 2. Confirmatory Factor Analysis Model for Exogenous Variables

Table 2. Standardized Regression Weight for Exogenous Variables

Standardized Regression Weights: (Group number 1 - Default model)

	Estimate
GPV5 <--- Green_Perceived_Value	.840
GPV4 <--- Green_Perceived_Value	.821
GPV3 <--- Green_Perceived_Value	.793
GPV2 <--- Green_Perceived_Value	.803
GPV1 <--- Green_Perceived_Value	.861
GPR5 <--- Green_Perceived_Risk	.751
GPR4 <--- Green_Perceived_Risk	.841
GPR3 <--- Green_Perceived_Risk	.716
GPR2 <--- Green_Perceived_Risk	.739
GPR1 <--- Green_Perceived_Risk	.833

Table 3. Model Fit Summary for Exogenous Variables

Model Measurement	Fit	Good Fit Cut Value	Fit Off Default Model	Result	Model Fit
RMSEA		0.05	–	0.085	Acceptable Fit
GFI		≥ 0.9		0.928	Good Fit
AGFI		≥ 0.9		0.883	Acceptable Fit
CMIN/DF		2 – 4		2.736	Good Fit
TLI		≥ 0.9		0.953	Good Fit
NFI		≥ 0.9		0.946	Good Fit

Next, let us analyze the measurement model standardized regression weight and model fit for the endogenous variables (Figure 3). Based on the table 4, all the indicators estimate values are above 0.5. Therefore, all of the indicators are valid. Furthermore, according to table 5, all the model fit measurements values still fulfil the cut off. RMSEA, GFI, AGFI, TLI, CMIN/DF, and NFI have a good model fit. Therefore, the author can conclude that both exogenous and endogenous variables have passed the confirmatory factor analysis and all the indicators are eligible for further research.

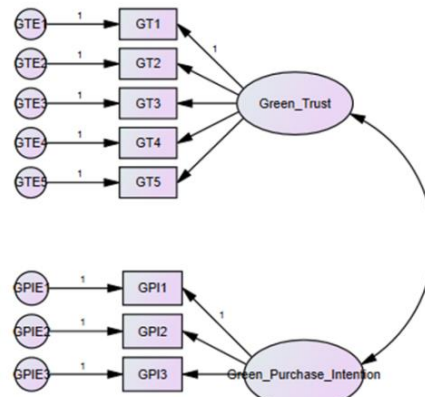

Figure 3. Confirmatory Factor Analysis Model for Endogenous Variables

Table 4. Standardized Regression Weight for Endogenous Variables

Standardized Regression Weights: (Group number 1 - Default model)

	Estimate
GT5 <--- Green_Trust	.779
GT4 <--- Green_Trust	.785
GT3 <--- Green_Trust	.787
GT2 <--- Green_Trust	.750
GT1 <--- Green_Trust	.760
GPI3 <--- Green_Purchase_Intention	.815
GPI2 <--- Green_Purchase_Intention	.748
GPI1 <--- Green_Purchase_Intention	.779

Table 5. Model Fit Summary for Exogenous Variables

Model Measurement	Fit	Good Fit Cut Value	Fit Off Default Model	Result	Model Fit
RMSEA		0.05	–	0.076	Good Fit
GFI		≥ 0.9		0.956	Good Fit
AGFI		≥ 0.9		0.916	Good Fit
CMIN/DF		2 – 4		2.414	Good Fit
TLI		≥ 0.9		0.970	Good Fit
NFI		≥ 0.9		0.966	Good Fit

Next, the author will analyze the convergent validity; variance extracted, and constructs reliability in order to ensure the validity and reliability of the variables towards the model. First, let us begin with checking the standardized regression weight in order to see the convergent validity of the model, which will be shown in table 6.

Table 6. Standardized Regression Weight of the Model

Standardized Regression Weights: (Group number 1 - Default model)

	Estimate
GPV5 <--- Green_Perceived_Value	.828
GPV4 <--- Green_Perceived_Value	.822
GPV3 <--- Green_Perceived_Value	.838
GPV2 <--- Green_Perceived_Value	.783
GPV1 <--- Green_Perceived_Value	.843
GPR5 <--- Green_Perceived_Risk	.755
GPR4 <--- Green_Perceived_Risk	.839
GPR3 <--- Green_Perceived_Risk	.715
GPR2 <--- Green_Perceived_Risk	.738
GPR1 <--- Green_Perceived_Risk	.833
GT5 <--- Green_Trust	.756
GT4 <--- Green_Trust	.800
GT3 <--- Green_Trust	.785
GT2 <--- Green_Trust	.738
GT1 <--- Green_Trust	.778
GPI3 <--- Green_Purchase_Intention	.795
GPI2 <--- Green_Purchase_Intention	.761
GPI1 <--- Green_Purchase_Intention	.789

According to the table 6 above, all the factor loadings are higher than 0.5, which indicates that all the indicators are reliable for further analysis. Next, the author will analyze the variance extracted as well as construct reliability of the model. The calculation of the both variance extracted and construct reliability will be conducted through Microsoft Excel, due to AMOS inability to calculate both estimation. The result will be shown in table 7.

Table 7. Variance Extracted and Construct Reliability

	AVE	CR
Green Perceived Value	0.678924	0.913519
Green Perceived Risk	0.60479	0.88397
Green Trust	0.59651	0.8808
Green Purchase Intention	0.61019	0.82426

Based on the table 7 above, all the variables' variance extracted (AVE) value is higher than 0.5 and construct reliability (CR) value is higher than 0.7.

The model which is used in the path analysis is different with the model used in the confirmatory factor analysis. In the confirmatory factor analysis, the author used the measurement model to analyze the whole concept. However, in the path analysis, the author will use the structural model, which will be show in the figure 4.

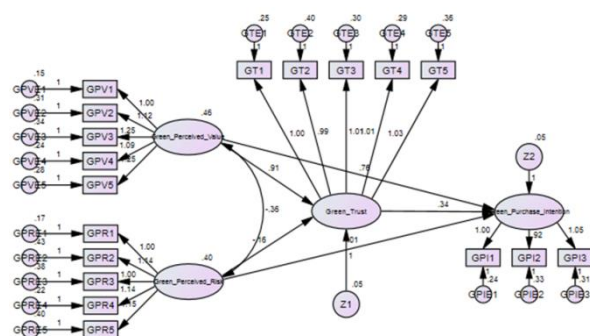

Figure 4. Path Analysis Model

Furthermore, for the SEM assumption test, the author will do a normality test as well as multicollinearity test in order to fulfil the SEM assumption test. The normality test will be done for three main models, which are green perceived value and green perceived risk towards green trust (first model), green perceived value and green perceived risk towards green purchase intention (second model), and green trust towards green purchase intention (third model). All of the result will be shown below.

Table 8. Kurtosis and Skewness

	Zskewness	Zkurtosis	Information
First Model	-1.273	1.254	Passed
Second Model	-0.936	0.929	Passed
Third Model	1.47	1.826	Passed

The standard critical value to say that the residuals are normally distributed is Z ranging between ±1.96 with significance level of 0.05. The author can conclude the whole model has passed the statistical test with Zskewness and Zkurtosis. Thus, all the residual is considered to be normally distributed and passes the normality test.

A good regression model will not have a multicollinearity problem within the data. This test can be done through multicollinearity statistic in the regression. In this research, the multicollinearity test will be done for the independent variables in the framework, which is green perceived value and green perceived risk towards green trust.

Table 9. Multicollinearity Statistic Test

Model	Tolerance	VIF
GPVT	0.443	2.255
GPRT	0.443	2.255

Based on the table 9, the VIF of every variables are far below 10 and the tolerance values are all greater than 0.1. Thus, there is no sign of multicollinearity problem in this model.

Table 10. Model Fit Summary for Exogenous Variables

Model Measurement	Fit	Good Fit Cut Off Value	Result Default Model	Model Fit
RMSEA		0.05 – 0.08	0.097	Not Fit
GFI		≥ 0.9	0.853	Acceptable Fit
AGFI		≥ 0.9	0.808	Not Fit
CMIN/DF		2 – 4	3.281	Good Fit
TLI		≥ 0.9	0.905	Good Fit
NFI		≥ 0.9	0.887	Acceptable Fit

Based on the table 10, 4 out of 6 model fit are acceptable, which mean the data already fulfil the minimum standard of model fit. Thus, this data is qualified for further analysis.

Next, in order to find the relationship between the endogenous variables and exogenous variables are significant or not, the author will analyze the structural model fit in this research.

Table 11. Standardized Regression Weight

Regression Weights: (Group number 1 - Default model)

		Estimate	S.E.	C.R.	P	Label
Green_Trust	<-- Green_Perceived_Value	.907	.085	10.631	***	par_15
Green_Trust	<-- Green_Perceived_Risk	-.161	.079	-2.045	.041	par_16
Green_Purchase_Intention	<-- Green_Trust	.337	.167	2.016	.044	par_17
Green_Purchase_Intention	<-- Green_Perceived_Value	.765	.178	4.304	***	par_18
Green_Purchase_Intention	<-- Green_Perceived_Risk	-.011	.089	-.125	.901	par_19
GPV5	<-- Green_Perceived_Value	1.250	.072	17.431	***	par_1
GPV4	<-- Green_Perceived_Value	1.085	.064	17.053	***	par_2
GPV3	<-- Green_Perceived_Value	1.250	.076	16.492	***	par_3
GPV2	<-- Green_Perceived_Value	1.118	.070	15.903	***	par_4
GPV1	<-- Green_Perceived_Value	1.000				
GPR5	<-- Green_Perceived_Risk	1.149	.088	13.007	***	par_5
GPR4	<-- Green_Perceived_Risk	1.145	.073	15.717	***	par_6
GPR3	<-- Green_Perceived_Risk	1.000	.081	12.327	***	par_7
GPR2	<-- Green_Perceived_Risk	1.139	.091	12.574	***	par_8
GPR1	<-- Green_Perceived_Risk	1.000				
GT1	<-- Green_Trust	1.000				
GT2	<-- Green_Trust	.988	.071	13.912	***	par_9
GT3	<-- Green_Trust	1.011	.065	15.620	***	par_10
GT4	<-- Green_Trust	1.007	.064	15.815	***	par_11
GT5	<-- Green_Trust	1.034	.070	14.867	***	par_12
GPI3	<-- Green_Purchase_Intention	1.047	.062	16.829	***	par_13
GPI2	<-- Green_Purchase_Intention	.918	.060	15.281	***	par_14
GPI1	<-- Green_Purchase_Intention	1.000				

Based on the table 11, each variable has a good positive and negative relationship, except the relationship between green perceived risk and green purchase intention which has a very low value of -0.09. However, this result is supported from the regression weight table 8 above, which indicate that green perceived risk has no significance impact towards green purchase intention. Therefore, the author can conclude that green perceived has a negative significant impact towards green purchase intention fully mediated by green trust.

CONCLUSION

Based on the overall research, there are several important findings that describe the influence between one variable to another. The first finding is that green perceived value has a positive influence towards green trust and green purchase intention of inverter air conditioner in Surabaya. When Surabaya’s consumers tend to believe that inverter air conditioner has a great value towards the environment compared to normal air conditioner and the product’s green performance is the same with what Surabaya’s consumers expected their green trust and green purchase intention for inverter air conditioner will increase.

The second finding is that green perceived risk has no direct impact towards green purchase intention. Green perceived risk influences the green purchase intention through the mediation of green trust. These resultsshow that the green perceived risk has P value of 0.901 towards green purchase intention. Therefore, the author can conclude that consumers in Surabaya tend to relate perceived risk of inverter air conditioner towards their trust of the inverter air conditioner. When Surabaya’s consumers perceive that inverter air conditioner has low risk towards the environment, they will have higher trust towards the inverter air conditioner, and it will lead to higher purchase intention.

The last finding is that green trust has a positive impact towards green purchase intention. When Surabaya’s consumers can trust the performance of inverter air conditioner, they will tend to have higher inverter air conditioner purchase intention.

Overall, the result of this research indicated that green perceived value, green perceived risk, and green trust have important roles to increase green purchase intention of inverter air conditioner in Surabaya. Green perceived value influences both green trust and green purchase intention of inverter air conditioner in Surabaya. While, green perceived risk influences green purchase intention of inverter air conditioner in Surabaya, through the mediation of green trust. However, when all the variables are looked closer, there is still room for improvements. Here are three recommendations that the author would like to contribute for electronic companies, especially for inverter air conditioner manufacturers.

First is bringing more green advanced technology in the industry. This research shows that green perceived value has a positive significance impact towards green trust and green purchase intention of inverter air conditioner in Surabaya. This means that inverter air conditioner manufacturers need to focus on increasing the green perceived value as high as possible. Increasing green perceived value can be done by bringing more green advanced technology to the table, such as giving more environmental friendly freon quality and more power efficient features. By giving more green advanced technologies, Surabaya’s consumers will tend to believe that inverter air conditioner has a higher value compared to the other normal air conditioner.

The second one is bringing new way of marketing strategy. This research also shows that green perceived risk has a negative significance impact towards green purchase intention through the mediation of green trust. This means that inverter air conditioner manufacturers need to focus on pushing down the green perceived risk in order to grab Surabaya's consumers trust towards inverter air conditioner. Decreasing green perceived risk can be done by creating a whole new marketing strategy which focuses on promoting the low environmental risk of using inverter air conditioner. By focusing on promoting the low environmental risk of using inverter air conditioner, Surabaya's consumers will tend to trust inverter conditioner more and it will lead to higher green purchase intention.

The final recommendation for inverter air conditioner manufacturers is to create a great relationship with Surabaya's consumers. The result in this research shows that green trust is take a significance role for mediating both green perceived value and green perceived risk towards green purchase intention. Creating a great relationship with Surabaya's consumers can be done by creating a green related event or communities, to communicate and educate Surabaya's consumers about the importance of green lifestyle and the importance of using inverter air conditioner. By creating a great relationship with Surabaya's consumers, it will not only increase their trust towards inverter air conditioner, but also increase their trust towards a certain inverter air conditioner manufacturers.

Last, the author also admits that this research is not perfect. There are two research limitations in this study. First, this study is limited to one specific product, which is inverter air conditioner. The further researches may use other green products, such as low-watt refrigerator, low-watt washing machine, LED-light bulb, etc, in order to get gain more prespective about consumer's prespective towards green products. The second one is this study is limited to Surabaya's consumers who ever bought inverter air conditioner. The further researches may use broaden scope of respondents from all over Java or even Indonesia. By broadening the scope of respondents, the results may represent broaden point of view to overcome some consumer's different characteristic caused by cultural differences.

REFERENCES

- Aaker. (1996). *Building Strong Brands*. New York: Free Press.
- Aisyah, A. (2012, September 6). Okezone. Retrieved from Okezone: <http://news.okezone.com/read/2012/09/06/340/685946/kerusakan-lingkungan-di-indonesia-capai-50>
- Al, H. e. (1998). *Multivariate Data Analysis*. New Jersey: Prentice Hall.
- Al, H. e. (2010). *Multivariate Data Analysis Seventh Edition*. United States: Pearson Prentice Hall.
- Al, L. e. (2011). The Different Effects of Online Consumer Reviews on Consumers' Purchas Intentions Depending on Trust in Online Shopping, Malls: an Advertising Perspective. *Internal Research*, 187-206.
- Azam Saeedi Kleshami, S. M. (2015). *Antecedents Factors Affecting Green Purchase Intention*.
- Bolton, D. (1991). A Multistage Model of Consumers' Assessment of Service Quality and Value. *International Journal of Service Industry Management*, 469 - 486.
- BPS. (2012). BPS. Retrieved from BPS: http://bps.go.id/tab_sub/view.php?kat=2&tabel=1&daftar=1&id_subyek=07¬ab=1
- BusinessWire. (2014). *Business Wire*. Retrieved from Business Wire: <http://www.businesswire.com/news/home/20140627005470/en/Research-Markets-2014-Report-Air-Conditioners-Market#.VOxFdmUd1Y>
- Chen. (2010). The Drivers of Green Brand Equity: Green Brand Image, Green Satisfaction, and Green Trust.
- Chen, & Chang. (2012). Enhance green purchase intentions: The roles of green perceived value, green perceived risk, and green trust. *Management Decision*, 510.
- Cooper D.R., S. P. (2014). *Business Research Method*. New York: McGraw-Hill.
- Dell. (2015). Statsoft. Retrieved from Statsoft: <http://www.statsoft.com/Textbook/Structural-Equation-Modeling>
- Didier, S. (2013). SFGate. Retrieved from SFGate: <http://homeguides.sfgate.com/global-warming-affect-daily-life-78745.html>
- Exeter, U. o. (1997, February 21). Exeter. Retrieved from Exeter: <http://people.exeter.ac.uk/SEGL/Lea/multivar2/pathanal.html>
- Gatra. (2015, January 22). Gatra. Retrieved from Gatra: <http://www.gatra.com/advetorial/130537-dukung-program-pemerintah-2015-panasonic-perkuat-bisnis-ac-ramah-lingkungan-untuk-pasar-indonesia.html>

- Ghozali, I. (2011). *Konsep dan Aplikasi Dengan Program AMOS 22*. Semarang: Universitas Diponegoro Semarang.
- Hijauku. (2013, May 30). Hijauku. Retrieved from Hijauku: <http://www.hijauku.com/2013/05/30/inilah-20-negara-pengguna-energi-terbesar-di-dunia/>
- Inhabitat. (2012, April 22). Inhabitat. Retrieved from Inhabitat: <http://inhabitat.com/why-we-need-earth-day-7-most-pressing-environmental-problems-we-need-to-solve/why-we-need-earth-day-global-warming-8/>
- IPCC. (2014). *Climate Change 2014 : Mitigation of Climate Change, IPCC Working Group III*. IPCC.
- Jacoby, & Kaplan. (1972). *The Components of Perceived Risk*.
- Ka, L. O. (2008). *Information Technology Acceptance of Patients With Chronic Illness. Development of a Model of Consumer Health*.
- Kline. (2011). *Principles and Practice of Structural Equation Modeling*. Guilford Press.
- LG. (2010, September 3). Makindinginmakinit. Retrieved from Makindinginmakinit: <http://www.makindinginmakinit.com/2010/09/03/perbedaan-antara-teknologi-inverter-dan-low-wattage/>
- Li, B. (2012). *Online Experiences and Virtual Goods Purchase Intention*. Internet Research, Vol 22.
- Murphy, & Enis. (1986). *An Effective Approach to Construct Value-Based Decision Model for Positioning Strategy*.
- Neraca. (2012, July 21). Neraca. Retrieved from Neraca: <http://www.neraca.co.id/teknologi/16651/Persaingan-Bisnis-AC-Semakin-Ketat>
- Oxford Dictionary, n. (2011, April 25). Oxford Dictionaries. Retrieved from Oxford Dictionaries: <http://www.oxforddictionaries.com/definition/english/global-warming>
- Patterson, & Spreng. (1997). *Modelling the relationship between perceived value, satisfaction and repurchase intentions in a business-to-business, services context*. International Journal of Service Industry Management.
- Philip. (2013). *Annual Report 2013*. Philip.
- Rekohadi, D. (2013, October 21). Surabaya Tribunews. Retrieved from Surabaya Tribunews: <http://surabaya.tribunews.com/2013/10/21/cuaca-panas-penjualan-ac-meningkat>
- Reyes, R. F. (2013). *Validation of a Performance Model in Entrepreneurship Based on Self-Efficacy, Personal Goal Orientation And Environment Goal Orientation Using Structural Equation Modeling*. Entrepreneurship, Leadership, and Structural Equation Modeling.
- Rudi. (2012, October 12). Lensa Indonesia. Retrieved from Lensa Indonesia: <http://www.lensaindonesia.com/2012/10/12/cuaca-panas-dongkrak-penjualan-ac-di-surabaya.html>
- Sarie. (2011, January 1). OkeZone. Retrieved from OkeZone: <http://techno.okezone.com/read/2011/01/01/324/409424/ac-midea-komitmen-ramah-lingkungan-dan-hemat>
- SPSS. (2010). *Introduction to Statistical Analysis with PASW Statistics*. Chichago: SPSS Inc.
- Statistic, L. (2013). *Statistics Laerd*. Retrieved from Statistics Laerd: <https://statistics.laerd.com/statistical-guides/pearson-correlation-coefficient-statistical-guide-2.php>
- Steven D'Alessandro, A. G. (2012). *Perceived Risk and Trust as Antecedents of Online Purchasing Behaviour in the USA Gemstone Industry*. Asia Pacific Journal of Marketing and Logistics.
- SWA. (2012, December 4). SWA. Retrieved from SWA: <http://swa.co.id/business-strategy/marketing/sejuknya-bisnis-ac-panasonic>
- Sweeny. (1999). *The role of perceived product quality and overall satisfaction*.
- Trucost. (2011, March 31). Unepfi. Retrieved from Unepfi: http://www.unepfi.org/fileadmin/documents/universal_ownership.pdf
- UCSUSA. (2014). UCSUSA. Retrieved from UCSUSA: <http://www.ucsusa.org/our-work/global-warming/science-and-impacts/global-warming-impacts#.VOq8MfmUd1Y>
- Wahyuni, N. D. (2014, January 24). Liputan6. Retrieved from Liputan6: <http://bisnis.liputan6.com/read/808478/131-juta-pelanggan-listrik-pra-bayar-ri-terbesar-di-dunia>
- Wheaton, B. B. (1977). *Assessing Reliability and Stability in Panel Models*. San Fransisco: Jossey-Bass.
- WWF. (n.d.). WWF. Retrieved from WWF: http://wwf.panda.org/how_you_can_help/live_green/energy_efficiency/
- WWF. (n.d.). WWF. Retrieved from WWF: http://wwf.panda.org/how_you_can_help/live_green/
- Zeithaml. (1988). *Consumer Perceptions of Price, Quality, and Value. A Means-end Model and Synthesis of Evidence*, 2-22.